

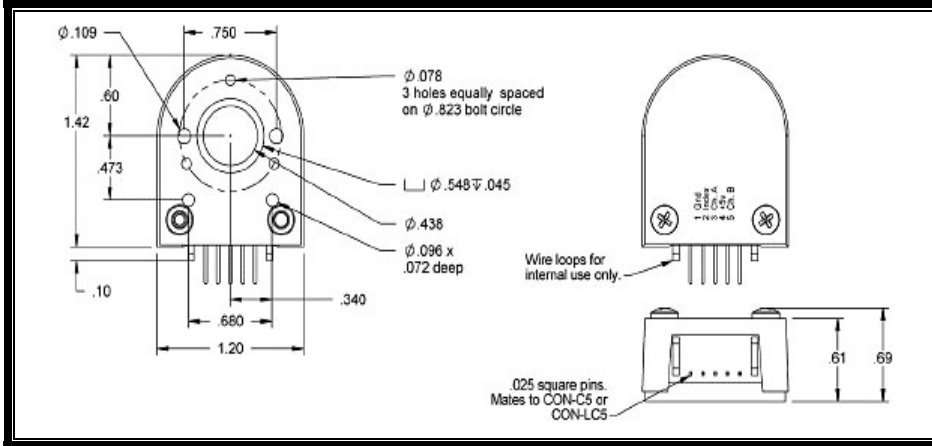

Option 1: Optical Encoder

Consult our Sales Office for Pricing



Interconnects / Functions

Pin Number	Function	Color
Pin 1	Ground	Brown
Pin 2	Index	Violet
Pin 3	Channel A	Blue
Pin 4	+ 5 Volts	Orange
Pin 5	Channel B	Yellow

****Encoder resolutions available: 32 PPR, 100 PPR, 250 PPR, 500 PPR, 1024 PPR**

(Use suffix "EU-xxx" after model # to designate the encoder and its resolution)

The standard modular encoder option, mounted integrally to the back of the motor, includes an index pulse, and 12" long flying leads with connector - mounted and tested before shipping.

Option 2: "IP-65" Optical Encoder, 1000 PPR STD

Consult our Sales Office for Pricing

Features index pulse, complementary output signals, IP-65 rated protection for harsh environments, 6 ft long cable.

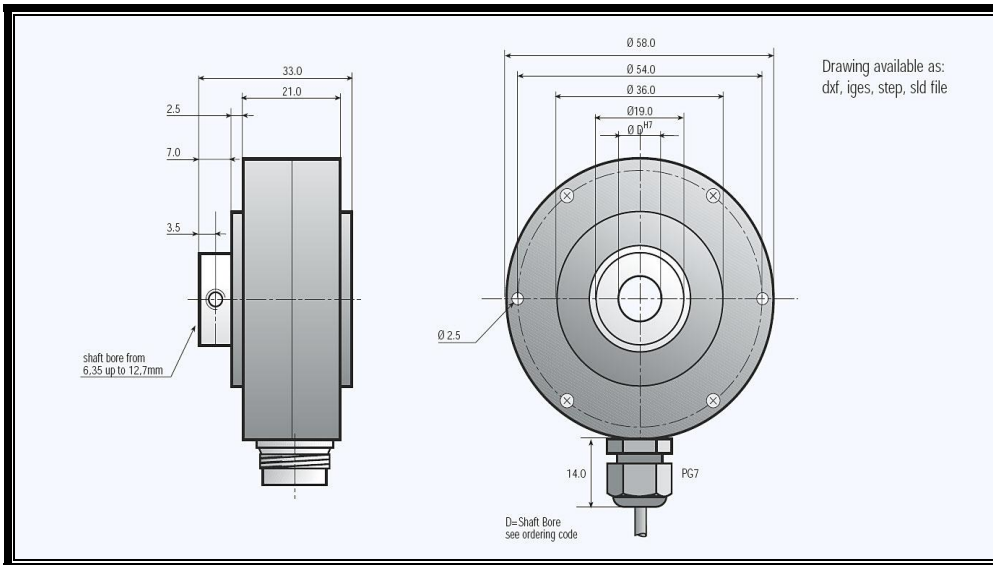

Ei-1000 Interconnects/Functions:

Function:	Wire Color
0 Volts	White
+ Volts	Brown
A	Green
B	Yellow
0	Grey
A-	Pink
B-	Blue
0-	Red

****Encoder Resolution 1000 PPR available from stock, but many other resolutions available.**

Consult our sales office for details. (Use Suffix "Ei-xxx" after model # to designate encoder and resolution)



OPTION 3: INTEGRAL BRAKE OPTION

Consult our Sales Office for Pricing

The MMP small frame gearmotors and motors, including the MMP D22 Series, MMP S22 Series and MMP B23 (brushless) series are sufficiently served by a 5 in-lb brake, when used correctly.

15 in-lb brakes also available for our larger sized motors / gearmotors. (specify "BR-015")

Typical dimensions 1.8" Diameter by 1.3" Long, with 24" leadwires

Typical (24V) brake current = 375 mA (12v, 24v, 36v and 48v Brakes are all 9 Watt devices)

Use suffix "BR-005" after model # to designate the brake and its' torque

IMPORTANT NOTE: IF THE BRAKE IS TO BE ENERGIZED BY A VOLTAGE LEVEL OTHER THAN THE SPECIFIED OPERATING VOLTAGE OF THE MOTOR, PLEASE SPECIFY THE BRAKE OPERATING VOLTAGE SEPARATELY. IF NOT OTHERWISE NOTED, IT IS ASSUMED THAT THE BRAKE'S COIL VOLTAGE WILL MATCH THAT OF THE MOTOR.

Please specify "BR-005" for standard "holding" brake (not to be used for dynamic braking)...

This part number suffix also identifies a "Failsafe" type brake (engages in the ABSENCE of input power to the coil).

For a "Power ON" brake, or a brake that is engaged with POWER APPLIED, please specify part number suffix "BR-005n".

Both of the above mentioned brakes are integrally mounted to the back of the motor, and are equipped with mounting holes and a shaft extension for an encoder.

The rear surface of the standard brake doubles as an encoder mounting surface. Most MMP brake motors and gearmotors are designed to include encoder compatibility.

***For additional details or assistance configuring the model number for brake and encoder options, please feel free to contact our sales offices.**

MIDWEST MOTION PRODUCTS

Design, Manufacturing & Distribution – Motion Control Equipment

10761 Ahern Avenue SE Watertown, MN 55388

Phone: 952-955-2626 Fax: 480-247-4096

www.midwestmotion.com

email: sales@midwestmotion.com